

Current instrument supporting transformer CTS 25

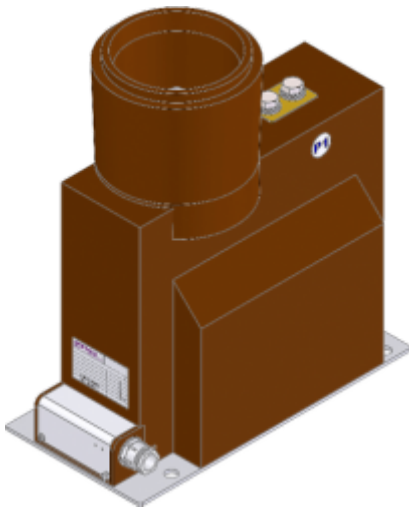

Supporting current instrument transformers CTS 25 are designed for the measurement and protection of the distributing facilities of high voltage for inner settings.

The value of the secondary current is 5 A or 1 A with the possibility of combination. The classes of accuracy for the circuits of measurement are 0.2, 0.5, 0.2S, 0.5S, 1, 3, for the circuit of protection are 5P, 10P and PX. The transformers comply with the required class of accuracy within the values from 25% to 100% of rated load.

Technical specifications

Highest voltage for equipment:

24/25 kV

Power frequency test voltage:

50 kV

Lightning impulse test voltage:

125 kV

Nominal primary current:

5 - 2500 A

Nominal secondary current:

5 A or 1 A

Rated short-time thermal current, I_{th}:

max 80 kA/1s (31.5 kA/3s)

Rated dynamic current, I_{dyn}:

max 200 kA

Rated continuous thermal current, I_{cth}:

120 % I_n

Accuracy class - measurement:

0.2, 0.5, 0.2S, 0.5S, 1, 3

Overcurrent factor - measurement:

FS5, FS10

Accuracy class - protection:

5P, 10P, PX

Overcurrent factor - protection:

5,10,15,20,25,30

Nominal power:

2,5 - 60 VA

Nominal frequency:

50 Hz

Length creepage:

280 mm

The limiting working current is 120% of I_N , according to the agreement of producer and customer it is possible to supply other values, for example 200% of I_N .

Transformers CTS 25 are constructed as transformers with single-turn or multi-turn primary winding. The up-to-date construction of these transformers allows the switching not only on the secondary side but also on the primary one. The primary switching can be easily mounted by the means of connection of two jumpers to the circuit by the means of two screws M8 (See "The Instructions for the mounting and operation"). Screws and jumpers are the part of the transformer.

The secondary winding is wound on a magnetic core made from grain oriented sheets, or alloys of nickel, iron and copper (permalloy).

The number of cores can be from 1 to 4 according to the request of customer and according to the required parameters.

All active parts of transformer are compound-insulated with epoxy-mixture. This material performs both the electrical insulating and the mechanical functions.

The mounting position of transformers is arbitrary. Transformers are fixed by the means of four screws in the holes in the basic plate. The primary terminals of transformers are equipped with screws M12. We recommend use terminal ends corresponding to the used cross-section of the conductor for attaching to the secondary outlets. The secondary terminal plate is equipped with the cover with sealing screw. Inside, there is the set with jumpers and small screws for the possibility of earth connection and short circuiting of the wiring. (See "The Instructions for the mounting and operation").

For the use of the transformers CTS 25 in distributors VH-IRODEL we produce and supply epoxy adapter, pin and special basic plate. In cases, where the supplement for the older types of transformers (by various producers) is required, we supply instruments

Weight:

28 kg

The temperature class:

E

Operation conditions:

operating temperature from -5 to + 40 °C

corresponds to temperature class -5/40 according to IEC 61869-1

Standard:

IEC 61869-1, IEC 61869-2, IEC 60068-2-11, IEC 61243-5, IEC 60071-1

CTS 25 on the modified basic plates that have identical mounting spacing to spacing of the substituted types.

Transformers CTS 25 complied with all the tests according to IEC 61869-1, IEC 61869-2, IEC 60068-2-11, IEC 61243-5, IEC 60071-1.

For the customer's request we provide official calibration.

It is possible to consult other technical parameters with the producer.

Technical drawings:

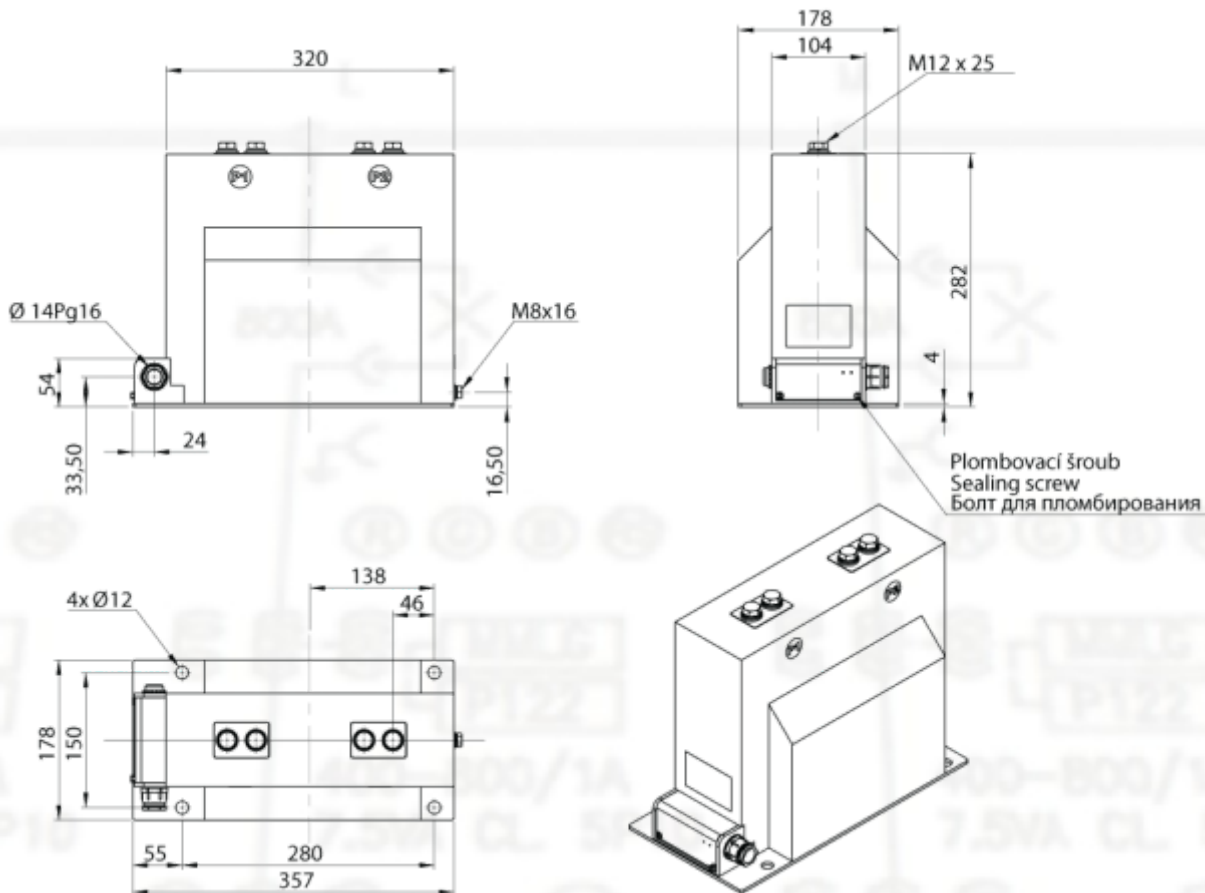

CTS 25

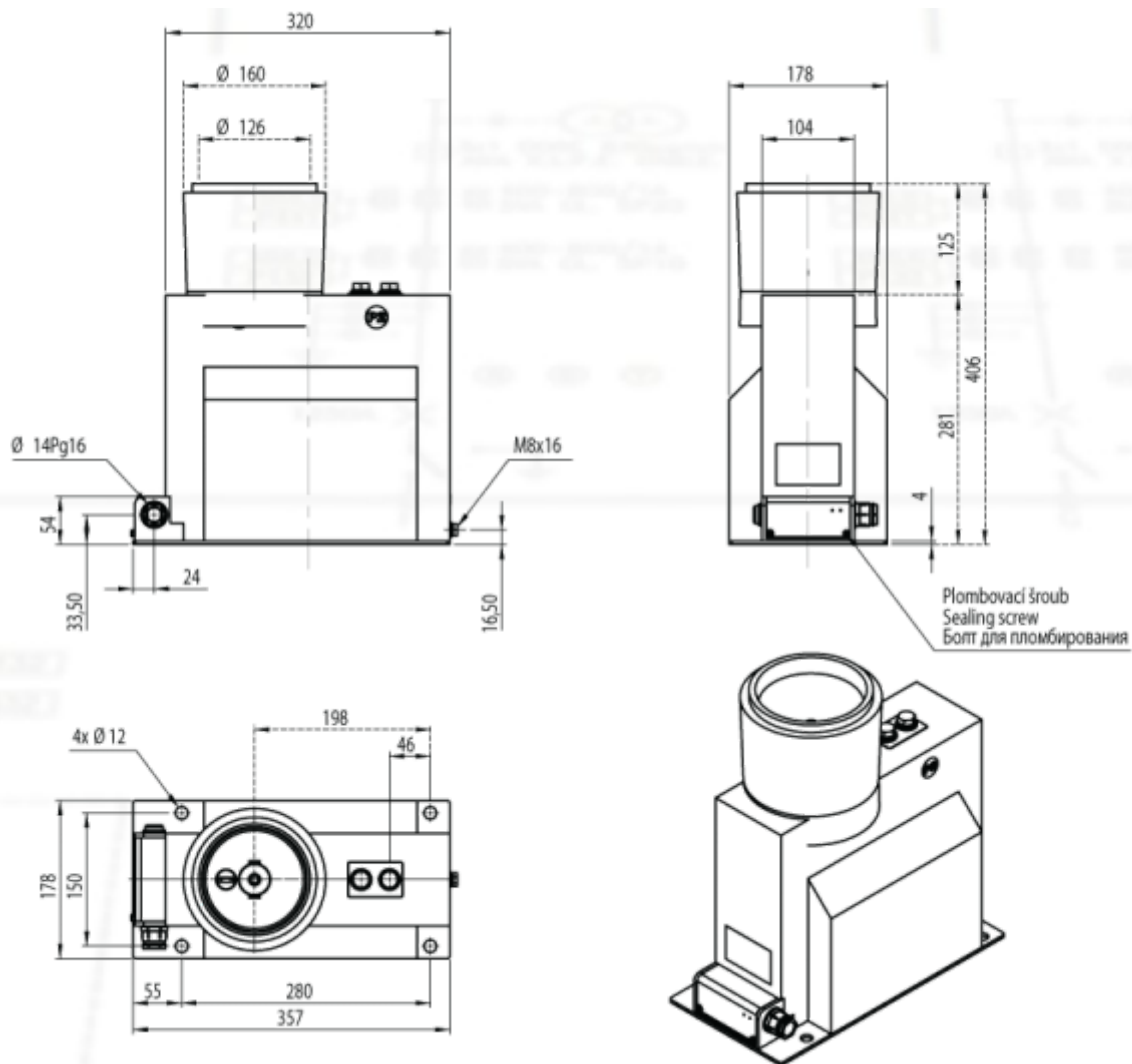

CTS 25 with IRODEL epoxy adapter

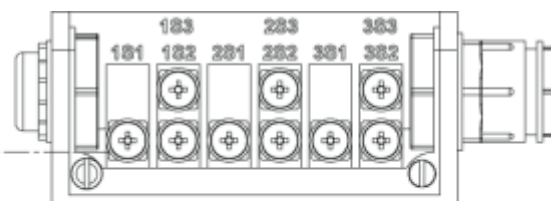

Sekundární svorkovnice
Secondary terminal
Клеммы вторичной обмотки

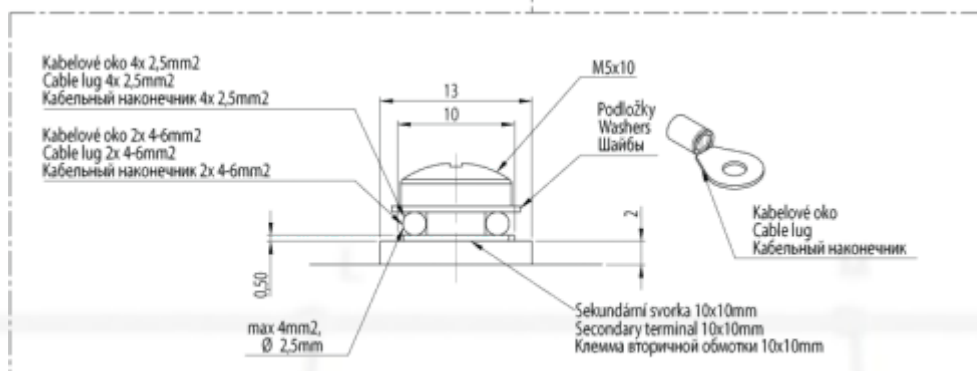

secondary terminal board

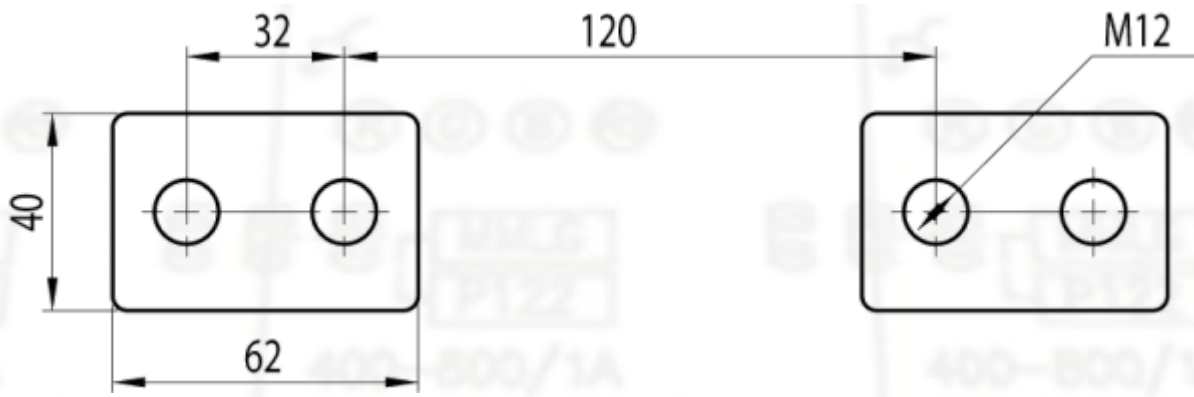

implementation of primary terminals up to 1250 A according to IEC

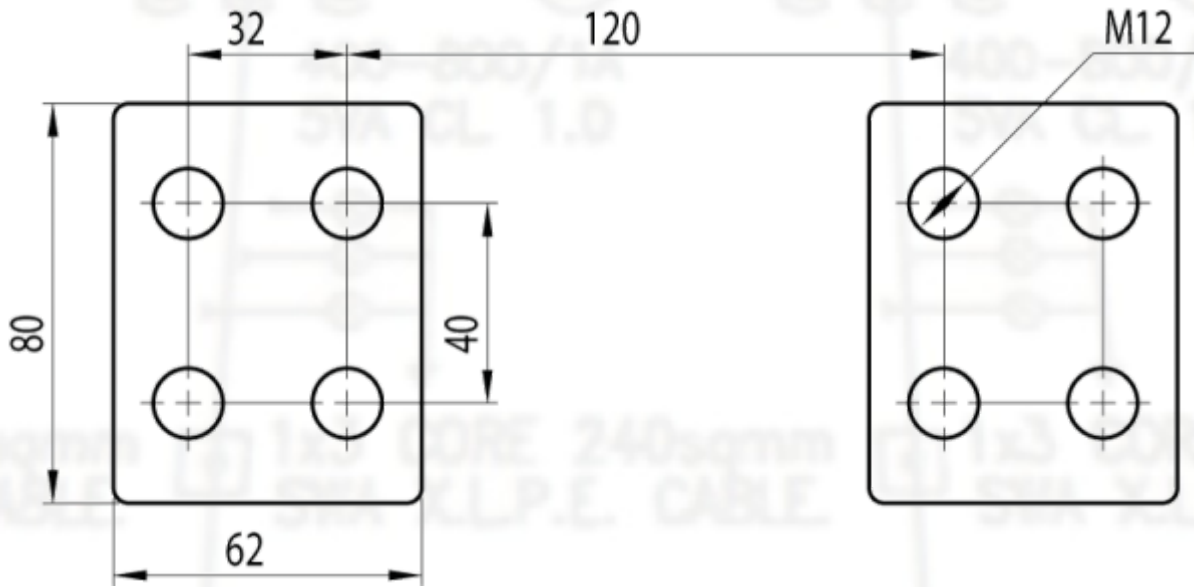

implementation of primary terminals from 1250 A to 1750 A according to IEC

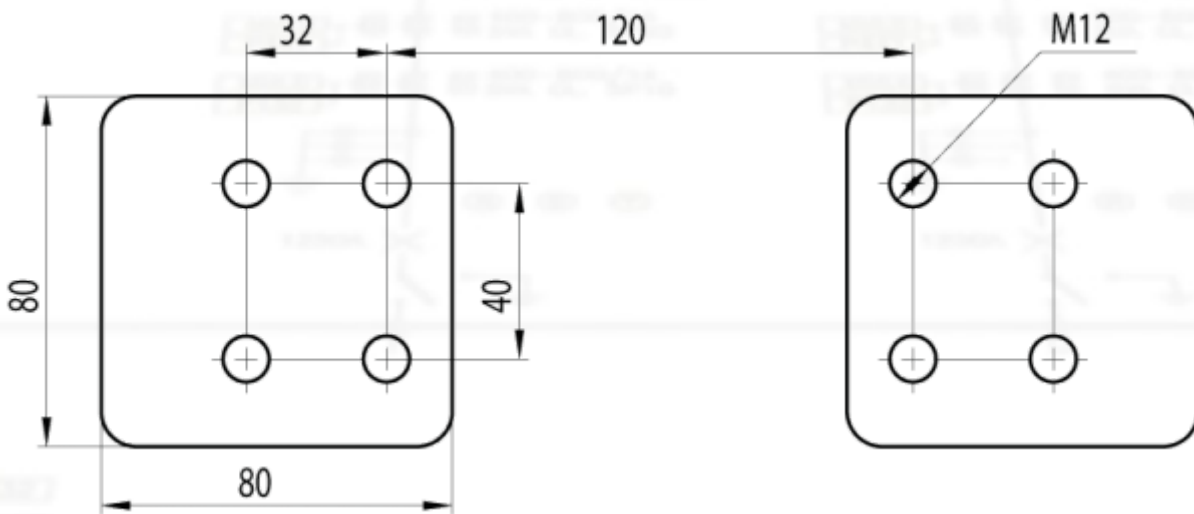

implementation of primary terminals above 1750 A according to IEC

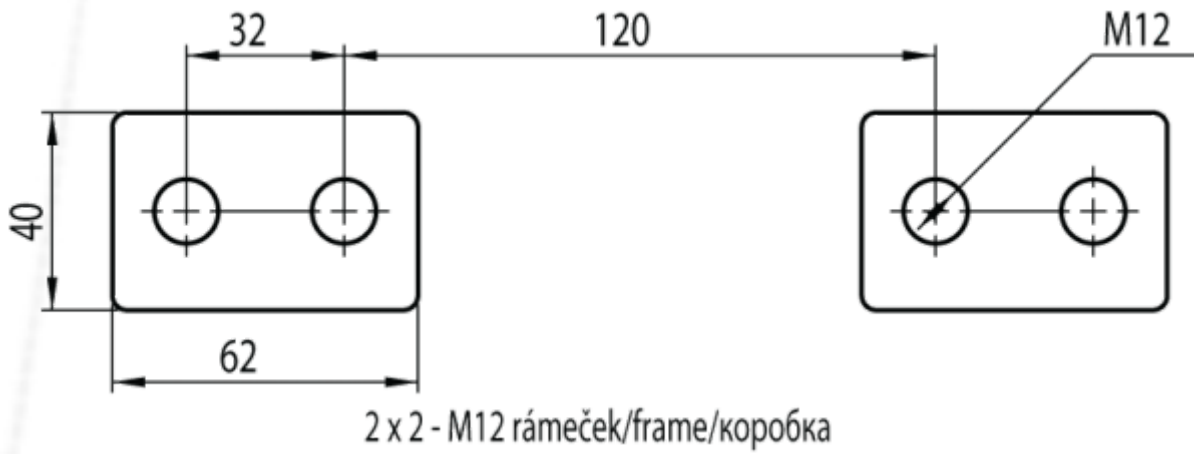

implementation of primary terminals up to 1250 A according to GOST

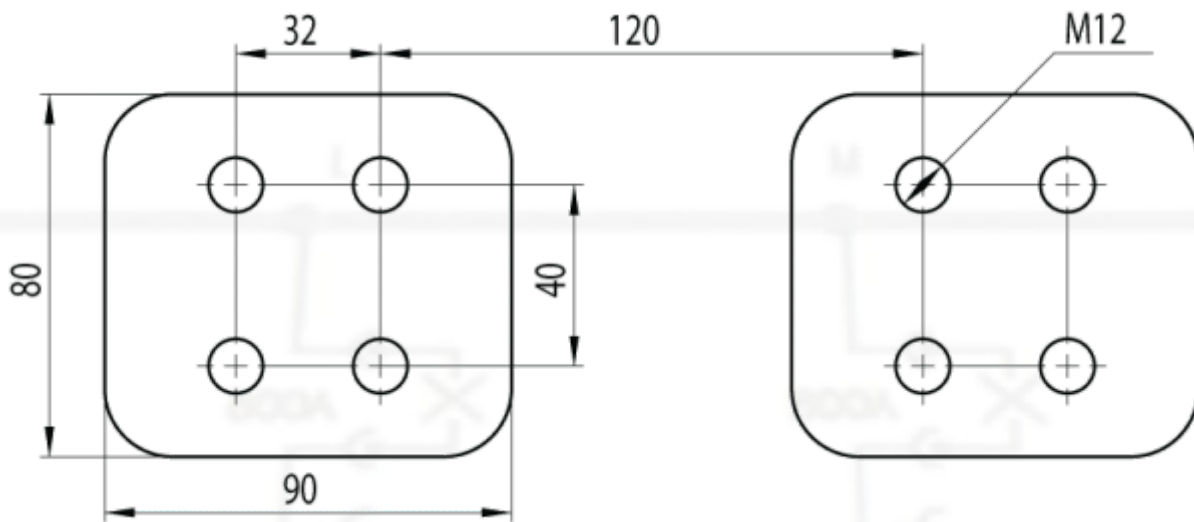

implementation of primary terminals from 1250 A to 1750 A according to GOST

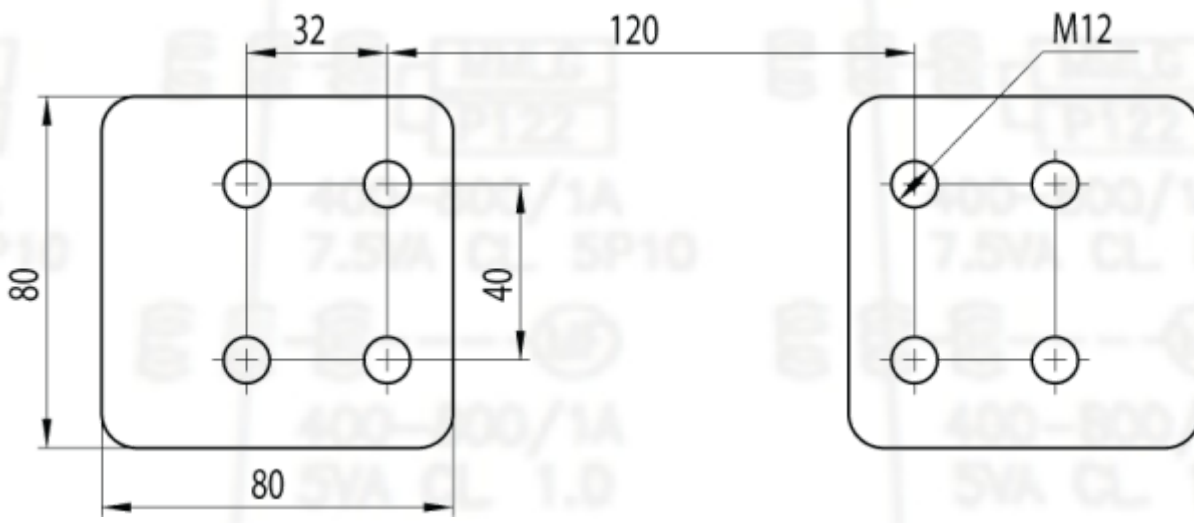

implementation of primary terminals above 1750 A according to GOST

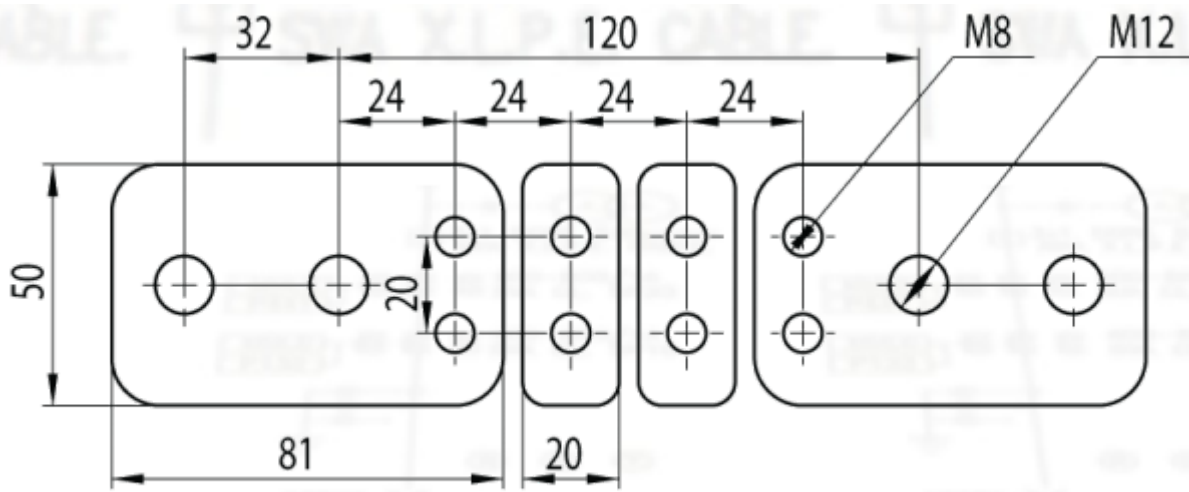

2 x 2 - M12 přepínatelné / switchable / переключаемый

primary switching

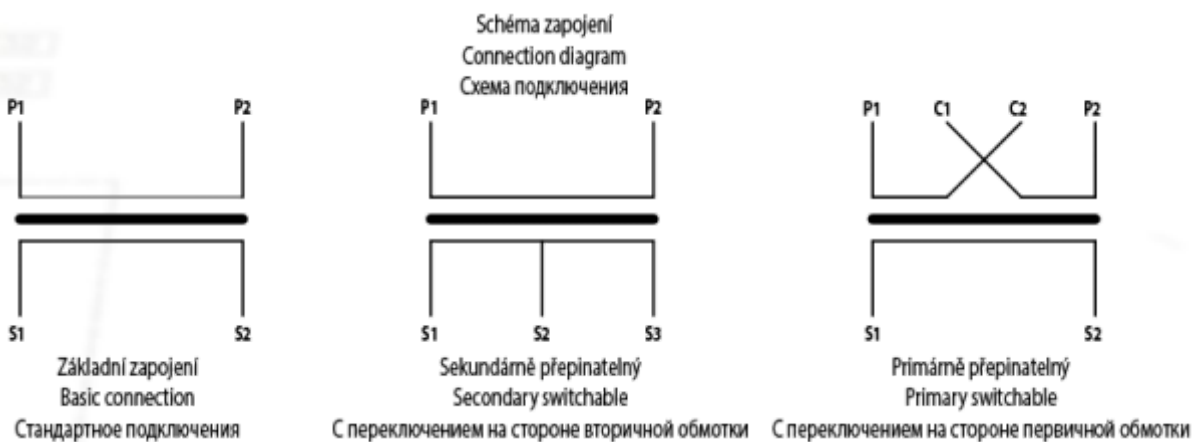

connection diagram

KPB INTRA s.r.o.
Ždánská 477
68501 Bučovice
Czech Republic

CEO: (+420) 603 481 128
obchod: (+420) 604 237 033
sales: (+420) 734 221 264
support: (+420) 603 862 464

tel.: (+420) 517 380 388
obchdo@kpb intra.cz
sales@kpb intra.cz
<http://www.kpb intra.cz>